

**FREE SPACE REQUIRED FOR MAINTENANCE**

**FREE SPACE REQUIRED FOR INSTALLATION**

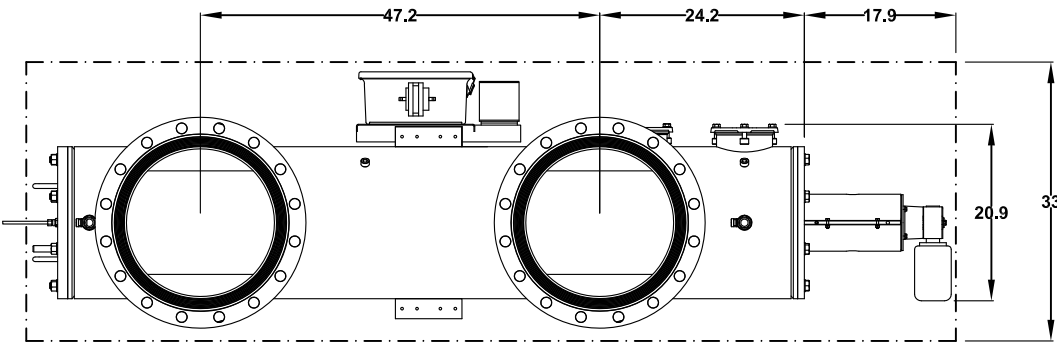
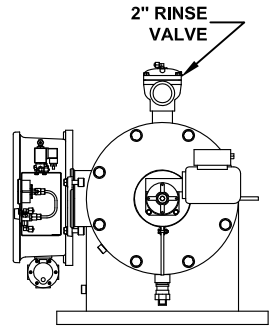
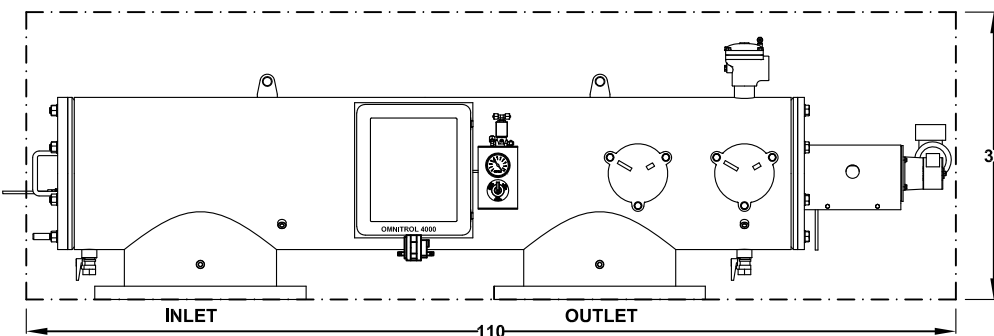
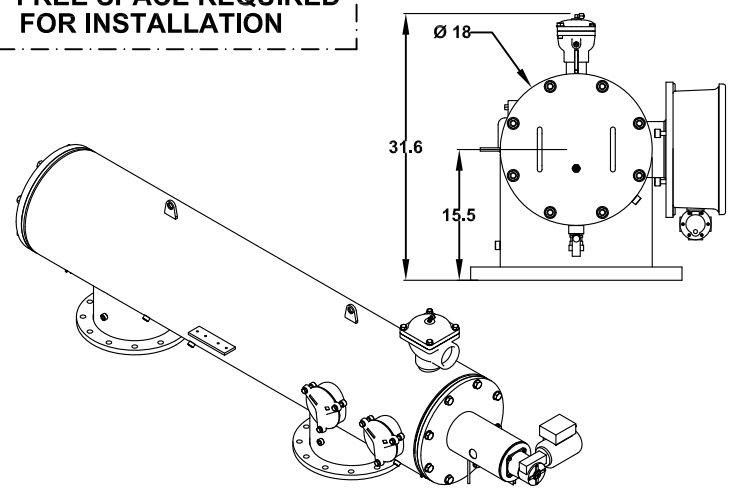

**TECHNICAL DATA**

<b>MAXIMUM FLOW RATE:</b>	6125 G.P.M.
<b>AVAILABLE SCREEN SIZES:</b>	10, 25, 50, 80, 100, 150, 200, 400, 800, 1000, 1500 MICRON
<b>OPEN SCREEN AREA:</b>	1560 SQ. INCHES
<b>MAXIMUM WORKING PRESSURE:</b>	150 PSIG
<b>MINIMUM INLET PRESSURE REQUIRED DURING RINSE CYCLE</b>	30 PSIG
<b>MAX. WORKING TEMPERATURE:</b>	150°F
<b>INLET/OUTLET FLANGES:</b>	18" ANSI 150#
<b>DRAIN VALVE CONNECTION:</b>	2"
<b>DRAIN HEADER SIZE:</b>	2" MINIMUM
<b>DRIVE MOTOR RATING:</b>	1/4 or 1/3 HP, TEFC
<b>INPUT VOLTAGES TO CONTROLLER:</b>	110-120 Vac - 60 Hz - 1 Phase 220-240 Vac - 50 Hz - 1 Phase
<b>APPROXIMATE WEIGHT - DRY:</b>	1080 LBS.
<b>APPROXIMATE SHIPPING WEIGHT:</b>	1290 LBS.
<b>APPROXIMATE WEIGHT FULL OF WATER:</b>	1685 LBS.

**ALL DIMENSIONS IN INCHES UNLESS INDICATED**

Orival Inc. reserves the right to modify filter dimensions without prior notice.

**DATA SHEET**  
**ORE/A-18-PS**  
**AUTOMATIC SELF-CLEANING FILTER**

**ORIVAL, INC.**  
213 S. VAN BRUNT ST.  
ENGLEWOOD, N.J. 07631  
TEL (201) 568-3311, FAX (201) 568-1916  
[www.orival.com](http://www.orival.com)  
[filters@orival.com](mailto:filters@orival.com)