

FREE SPACE REQUIRED
FOR MAINTENANCE

ALL DIMENSIONS IN INCHES UNLESS INDICATED

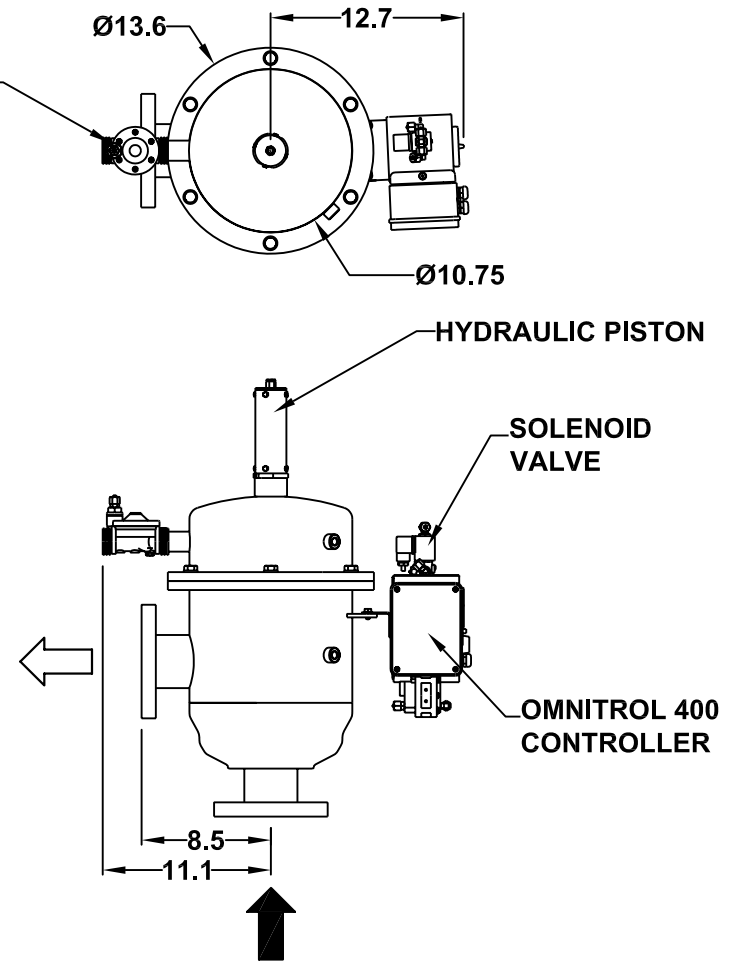
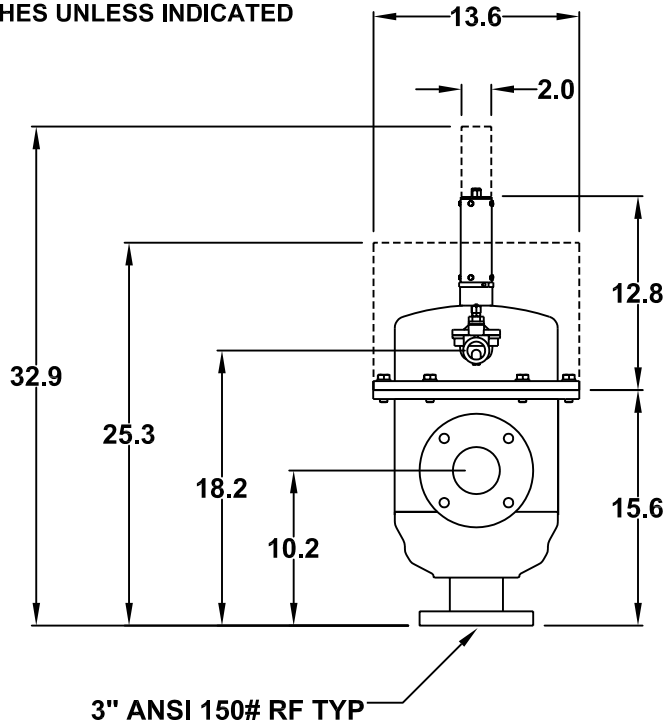

TECHNICAL DATA

MAXIMUM FLOW RATE:	175 G.P.M.
AVAILABLE SCREEN MICRON SIZES:	5, 10, 15, 25, 30, 40, 50, 80, 100, 120, 150, 200, 400, 800, 1000, 1500, 3000
OPEN AREA STD. SCREEN :	120 SQ. INCHES
OPEN AREA HIGH PERFORMANCE SINTERED MULTI-LAYERED SCREEN:	180 SQ. INCHES
MAXIMUM WORKING PRESSURE:	150 PSIG
MINIMUM INLET PRESSURE REQUIRED DURING RINSE CYCLE:	30 PSIG
MAX. WORKING TEMPERATURE:	150°F
INLET/OUTLET CONNECTIONS:	3" ANSI 150# RF
DRAIN VALVE CONNECTION:	1" FEMALE
DRAIN HEADER SIZE:	1" MINIMUM
APPROX. EMPTY WEIGHT:	95 LBS.
APPROX. FULL OF WATER WEIGHT:	130 LBS.

DATA SHEET

ORG-030-LE

AUTOMATIC SELF-CLEANING FILTER

Orival Inc. reserves the right to modify filter dimensions without prior notice.

ORIVAL, INC.
 213 S. VAN BRUNT ST.
 ENGLEWOOD, N.J. 07631
 TEL (800) 567-9767, (201) 568-3311
 FAX (201) 568-1916
 www.orival.com
 filters@orival.com