

General Dimensions

Model No.	Pipe Size (in.)	Length "A" (in.)	Height "B" (in.)	Screen Diameter "C Ø" (in.)	Body Diameter "D Ø" (in.)
ORL-050-IS	1/2	6-11/16	10-15/16	1-3/4	3-13/16
ORL-075-IS	3/4	7	10-15/16	1-3/4	3-13/16
ORL-100-IS	1	8-1/4	10-15/16	1-3/4	3-13/16
ORL-125-IS	1-1/4	8-3/4	10-15/16	1-3/4	3-13/16
ORL-150-IS	1-1/2	9-11/16	14	2-5/16	4-3/4
ORL-200-IS	2	10-1/2	14	2-5/16	4-3/4

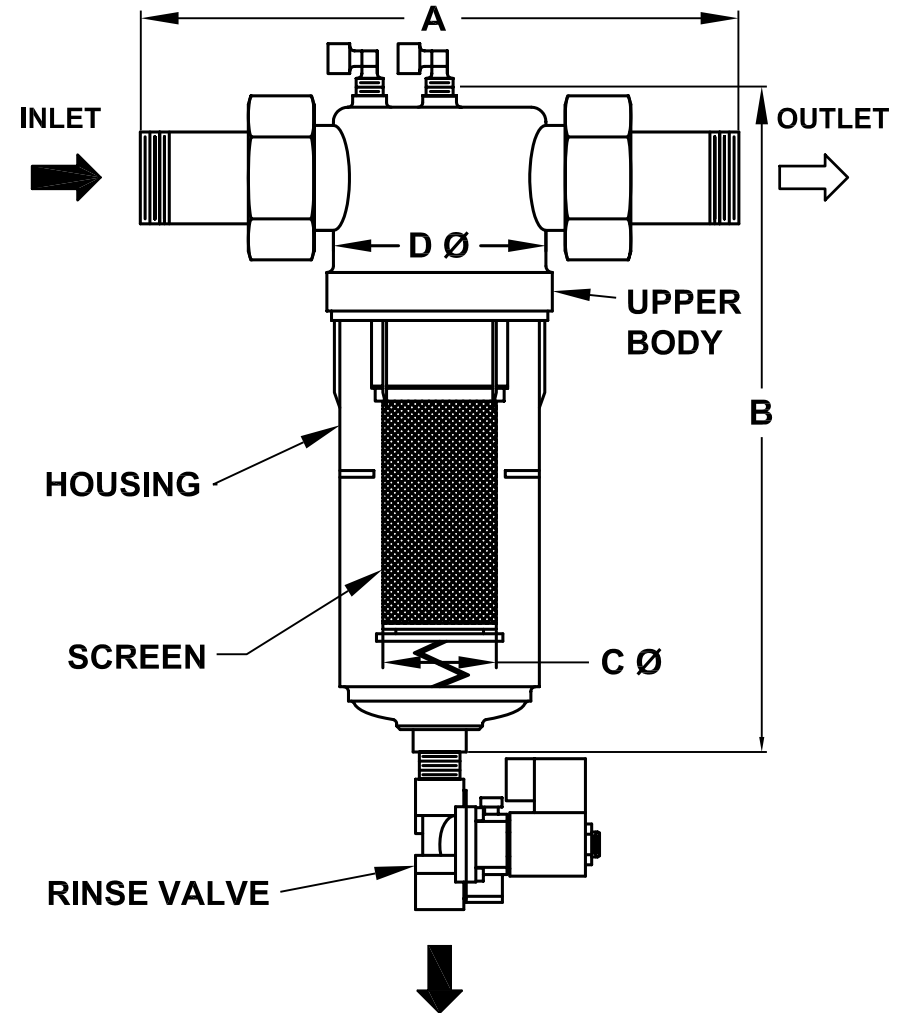

Flow Rate (gpm) vs. Pressure Drop

Pressure Drop (psi)	Pipe Size (in.)					
	1/2	3/4	1	1-1/4	1-1/2	2
1	8	11	18	20	26	30
2	12	16	25	28	36	42
3	14	19	31	35	44	51
4	16	22	36	40	51	59
5	18	25	40	45	57	66

Subject to change without notice.
ALL DIMENSIONS IN INCHES UNLESS OTHERWISE STATED

DRAWN BY:
GW
APPVD.:
--
DATE:
08/06/02
SCALE:
N.T.S.



ORIVAL, INC. 40 N. Van Brunt St., Englewood, NJ 07631
(201) 568-3311; Fax: (201) 568-1916

ORL SERIES GENERAL DIMENSIONS

DRAWING NO. ORL-xxx-IS

SHEET:
1 of 1

REV	DESCRIPTION	DATE	APP'D