

**FREE SPACE REQUIRED  
FOR MAINTENANCE**

**FREE SPACE REQUIRED  
FOR INSTALLATION**

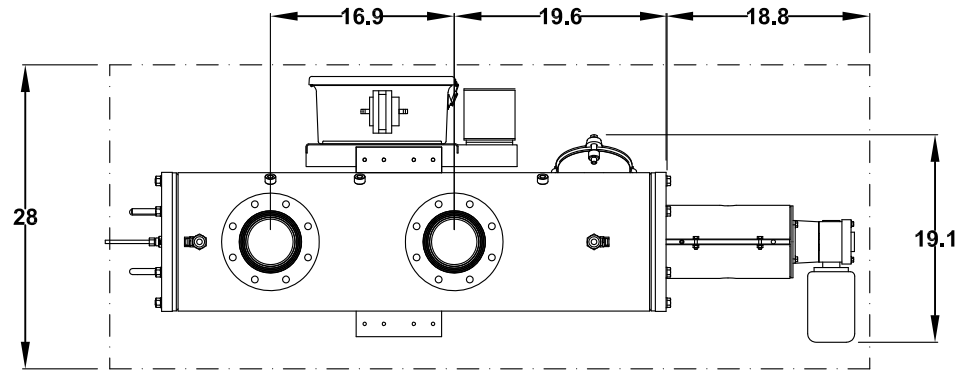
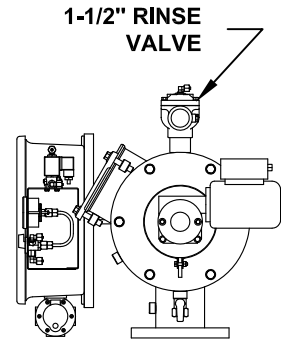
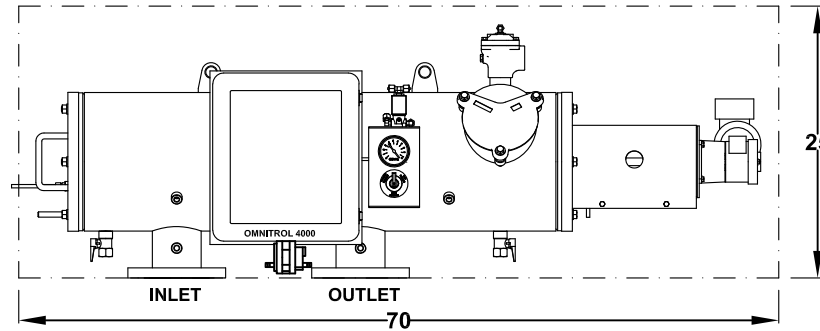
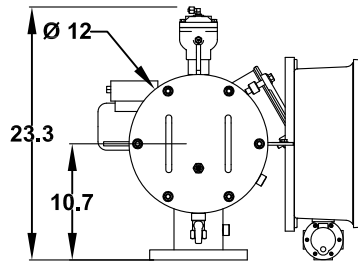
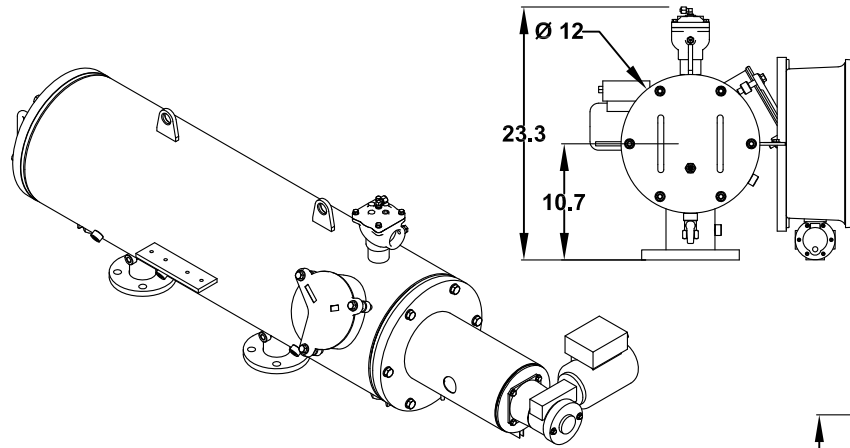
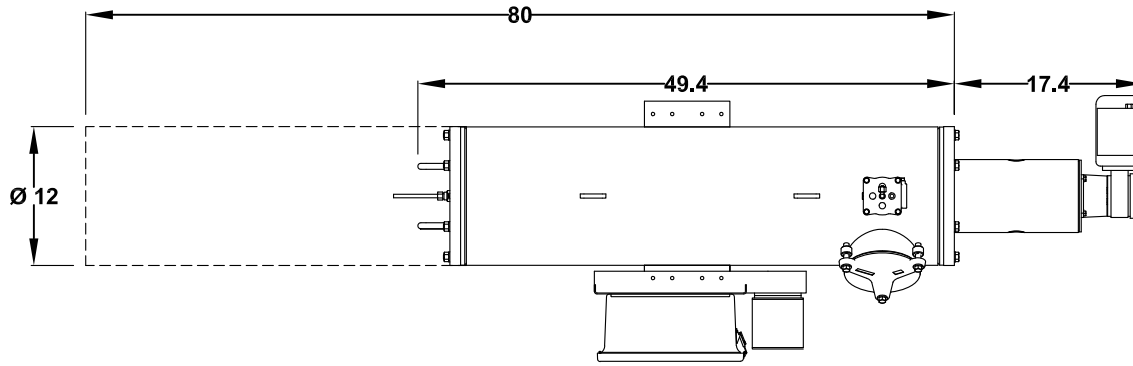

**ALL DIMENSIONS IN INCHES UNLESS INDICATED**

Orival Inc. reserves the right to modify filter dimensions without prior notice.

### TECHNICAL DATA

MAXIMUM FLOW RATE:	350 G.P.M.
AVAILABLE SCREEN SIZES:	10, 25, 50, 80, 100,150, 200, 400, 800, 1000, 1500 MICRON
OPEN SCREEN AREA:	390 SQ. INCHES
MAXIMUM WORKING PRESSURE:	150 PSIG
MINIMUM INLET PRESSURE REQUIRED DURING RINSE CYCLE	30 PSIG
MAX. WORKING TEMPERATURE:	150°F
INLET/OUTLET FLANGES:	4" ANSI 150#
DRAIN VALVE CONNECTION:	1-1/2"
DRAIN HEADER SIZE:	1-1/2" MINIMUM
DRIVE MOTOR RATING:	1/4 or 1/3 HP, TEFC
INPUT VOLTAGES TO CONTROLLER:	110-120 Vac - 60 Hz - 1 Phase 220-240 Vac - 50 Hz - 1 Phase
APPROXIMATE WEIGHT - DRY:	375 LBS.
APPROXIMATE SHIPPING WEIGHT:	460 LBS.
APPROXIMATE WEIGHT FULL OF WATER:	480 LBS.

### DATA SHEET

# ORE/A-04-PM

**AUTOMATIC SELF-CLEANING FILTER**

**ORIVAL, INC.**

213 S. VAN BRUNT ST.

ENGLEWOOD, N.J. 07631

TEL (201) 568-3311, FAX (201) 568-1916

[www.orival.com](http://www.orival.com)

[filters@orival.com](mailto:filters@orival.com)