

**FREE SPACE REQUIRED FOR MAINTENANCE**

**FREE SPACE REQUIRED FOR INSTALLATION**

**ALL DIMENSIONS IN INCHES UNLESS INDICATED**

Orival Inc. reserves the right to imodify filter dimensions without prior notice.

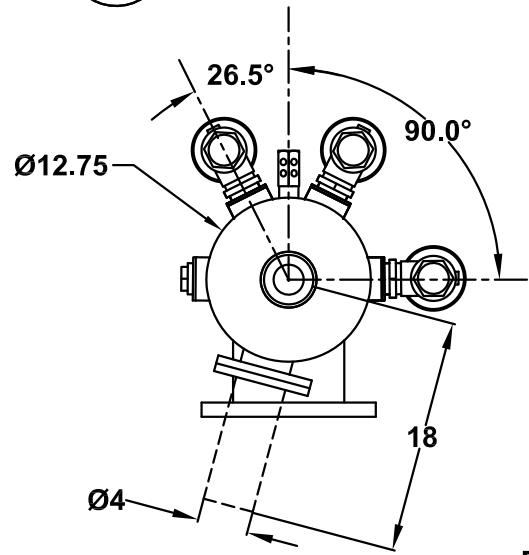
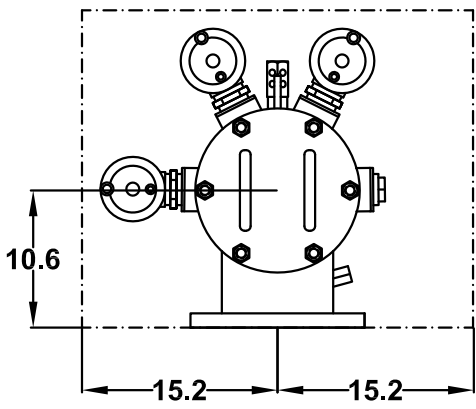
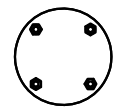
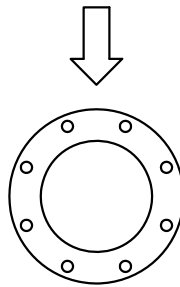
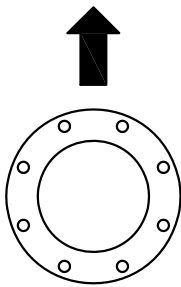

**TECHNICAL DATA**

MAXIMUM FLOW RATE:	1320 G.P.M.
AVAILABLE SCREEN MICRON SIZES:	5, 10, 15, 25, 30, 40, 50, 80, 100, 120, 150, 200, 400, 800, 1000, 1500, 3000
OPEN AREA STANDARD SCREEN :	713 SQ. INCHES
OPEN AREA HIGH PERFORMANCE SINTERED MULTI-LAYERED SCREEN:	1070 SQ. INCHES
MAXIMUM WORKING PRESSURE:	150 PSIG
MINIMUM INLET PRESSURE REQUIRED DURING RINSE CYCLE:	30 PSIG
MAX. WORKING TEMPERATURE:	150°F
INLET/OUTLET FLANGES:	8" ANSI 150#
DRAIN VALVE CONNECTION:	3 X 2" THREADED
DRAIN HEADER SIZE:	4" MINIMUM
APPROX. EMPTY WEIGHT:	355 LBS.
APPROX. FULL OF WATER WEIGHT:	755 LBS.

**DATA SHEET**

**OR-08-PE**

**AUTOMATIC SELF-CLEANING FILTER**

REV 4/14

**ORIVAL, INC.**  
 213 S. VAN BRUNT ST.  
 ENGLEWOOD, N.J. 07631  
 TEL (201) 568-3311, FAX (201) 568-1916  
 www.orival.com, filters@orival.com