

**FREE SPACE REQUIRED FOR MAINTENANCE**

**FREE SPACE REQUIRED FOR INSTALLATION**

**ALL DIMENSIONS IN INCHES UNLESS INDICATED**

Orival Inc. reserves the right to modify filter dimensions without prior notice.

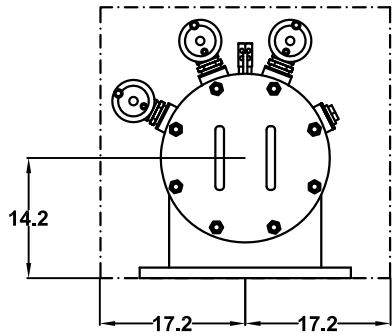
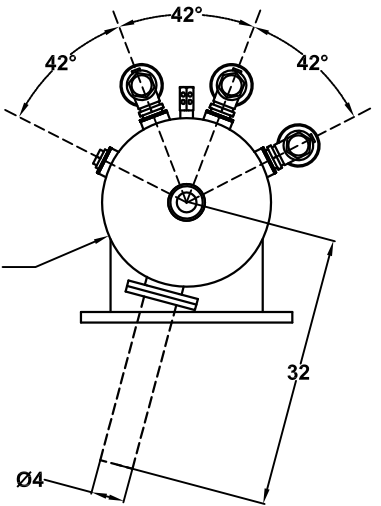
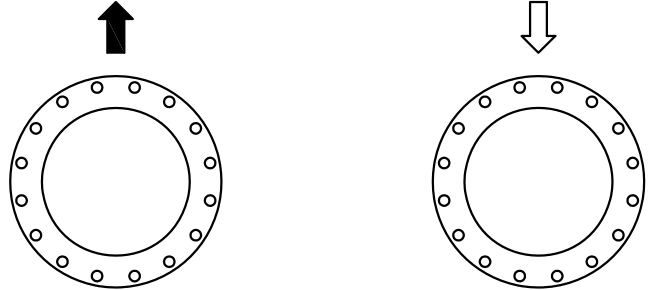

<b>TECHNICAL DATA</b>	
<b>MAXIMUM FLOW RATE:</b>	6125 G.P.M.
<b>AVAILABLE SCREEN MICRON SIZES:</b>	5, 10, 15, 25, 30, 40, 50, 80, 100, 120, 150, 200, 400, 800, 1000, 1500, 3000
<b>OPEN AREA STANDARD SCREEN :</b>	1070 SQ. INCHES
<b>OPEN AREA HIGH PERFORMANCE SINTERED MULTI-LAYERED SCREEN:</b>	1605 SQ. INCHES
<b>MAXIMUM WORKING PRESSURE:</b>	150 PSIG
<b>MINIMUM INLET PRESSURE REQUIRED DURING RINSE CYCLE:</b>	30 PSIG
<b>MAX. WORKING TEMPERATURE:</b>	150°F
<b>INLET/OUTLET FLANGES:</b>	18" ANSI 150#
<b>DRAIN VALVE CONNECTION:</b>	3 X 2" THREADED
<b>DRAIN HEADER SIZE:</b>	4" MINIMUM
<b>APPROX. EMPTY WEIGHT:</b>	1025 LBS.
<b>APPROX. FULL OF WATER WEIGHT:</b>	2185 LBS.

**DATA SHEET**

**OR-18-PS**

**AUTOMATIC SELF-CLEANING FILTER**

REV 4/14

**ORIVAL, INC.**  
 213 S. VAN BRUNT ST.  
 ENGLEWOOD, N.J. 07631  
 TEL (201) 568-3311, FAX (201) 568-1916  
 www.orival.com, filters@orival.com