

FREE SPACE REQUIRED
FOR MAINTENANCE

FREE SPACE REQUIRED
FOR INSTALLATION

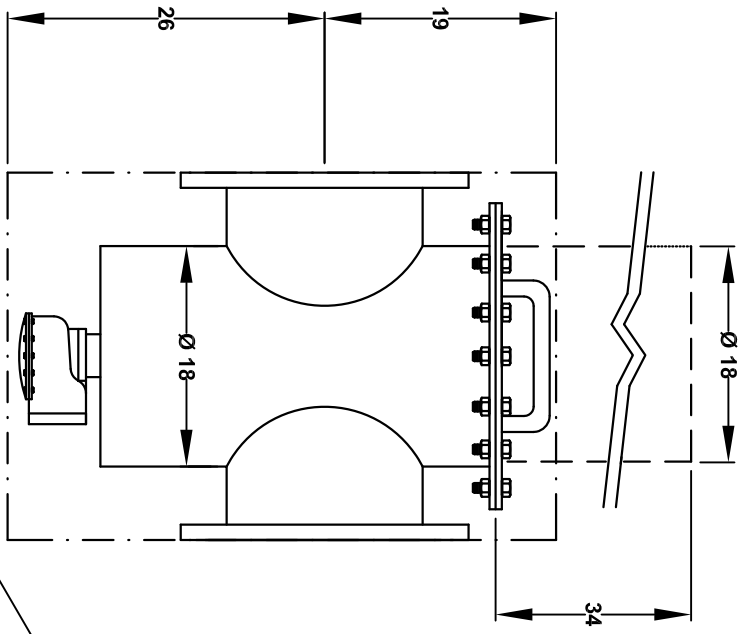

TOP VIEW WITH Ø 25
COVER REMOVED

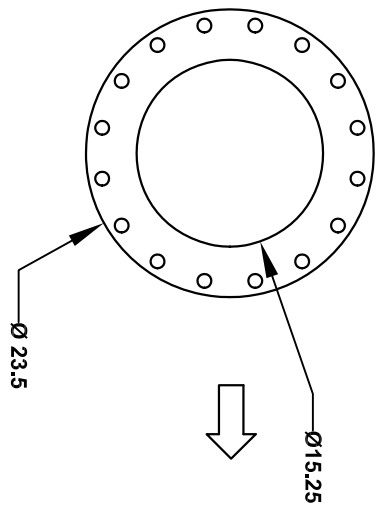
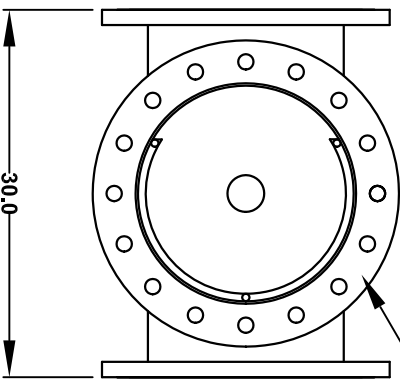
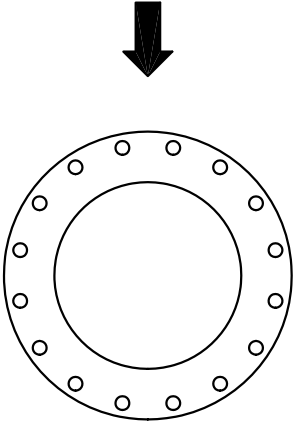

ALL DIMENSIONS IN INCHES UNLESS INDICATED

Orival Inc. reserves the right to modify filter dimensions without prior notice.

TECHNICAL DATA

MAXIMUM FLOW RATE:	5000 G.P.M.
AVAILABLE SCREEN SIZES:	3000, 5000 & 8000 MICRON
MAXIMUM WORKING PRESSURE:	150 PSIG
INLET/OUTLET FLANGES:	16" ANSI 150#
DRAIN VALVE CONNECTION:	3"
DRY / SHIPPING WEIGHT:	600 / 850 POUNDS

ORC-16

AUTOMATIC SELF-CLEANING FILTER

ORIVAL, INC.
 213 S. VAN BRUNT ST.
 ENGLEWOOD, N.J. 07631
 TEL (201) 568-3311, FAX (201) 568-1916
 www.orival.com -- filters@orival.com