

**FREE SPACE REQUIRED
FOR MAINTENANCE**

**FREE SPACE REQUIRED
FOR INSTALLATION**

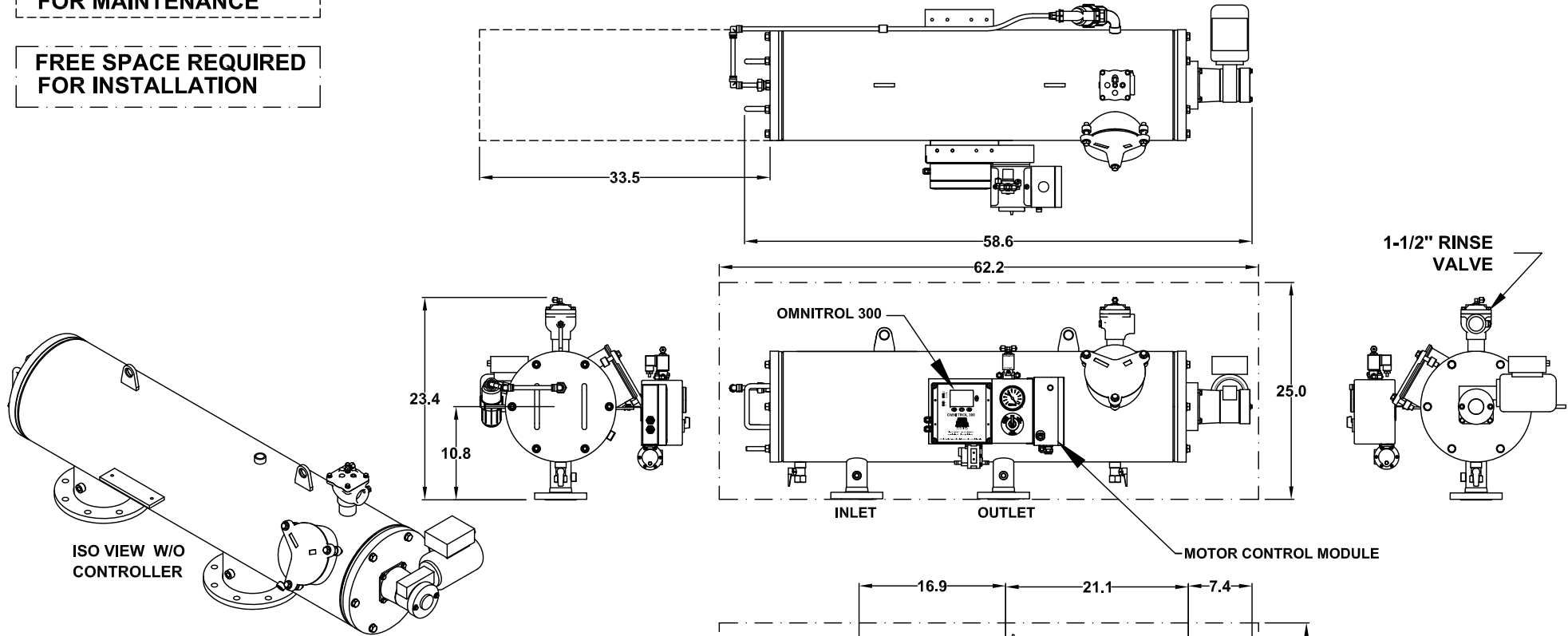

ISO VIEW W/O
CONTROLLER

TECHNICAL DATA

MAXIMUM FLOW RATE:	110 G.P.M.
AVAILABLE SCREEN MICRON SIZES:	5, 10, 15, 25, 30, 40, 50, 80, 100, 120, 150, 200, 300, 400, 800, 1000, 1500, 3000
OPEN SCREEN AREA:	390 SQ. INCHES
MAXIMUM WORKING PRESSURE:	150 PSIG
MINIMUM INLET PRESSURE REQUIRED DURING RINSE CYCLE	30 PSIG
MAX. WORKING TEMPERATURE:	150°F
INLET/OUTLET FLANGES:	2" ANSI B16.5 150# RF
DRAIN VALVE CONNECTION:	1-1/2"
DRAIN HEADER SIZE:	1-1/2" MINIMUM
DRIVE MOTOR RATING:	1/3 HP, TEFC
AVAILABLE INPUT VOLTAGES TO CONTROLLER and MOTOR:	110-120 Vac - 60 Hz - 1 Phase or 220-240 Vac - 50 Hz - 1 Phase
APPROXIMATE WEIGHT - DRY:	345 LBS.
APPROXIMATE SHIPPING WEIGHT:	430 LBS.
APPROXIMATE WEIGHT FULL OF WATER:	450 LBS.

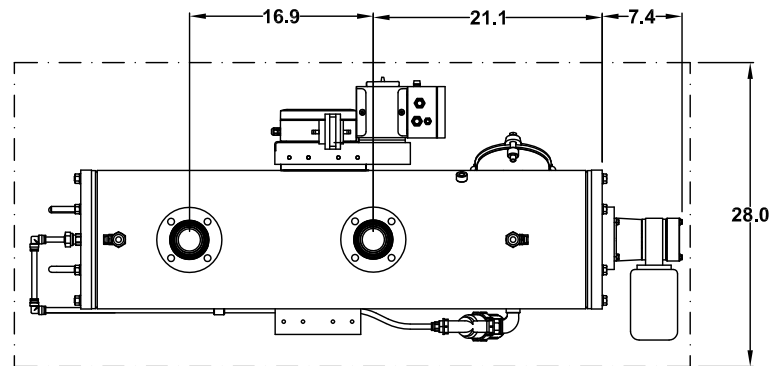

ALL DIMENSIONS IN INCHES UNLESS INDICATED

Orval Inc. reserves the right to modify filter dimensions without prior notice.

DATA SHEET
ORE/B-02-PS
AUTOMATIC SELF-CLEANING FILTER

ORIVAL, INC.
213 S. VAN BRUNT ST.
ENGLEWOOD, N.J. 07631
TEL (201) 568-3311, FAX (201) 568-1916
www.orival.com
filters@orival.com