

FREE SPACE REQUIRED  
FOR MAINTENANCE

FREE SPACE REQUIRED  
FOR INSTALLATION

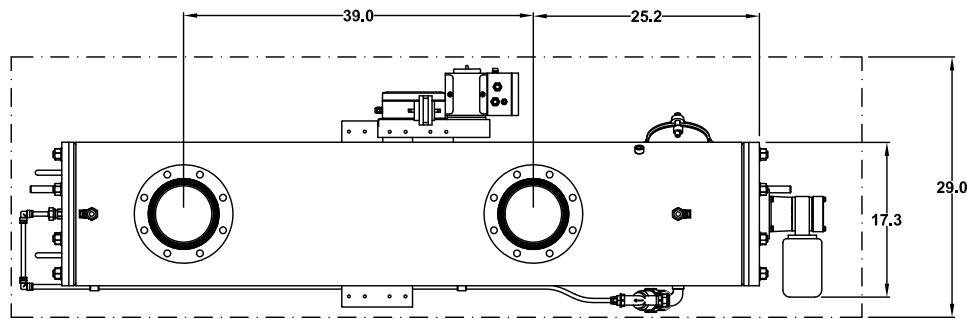
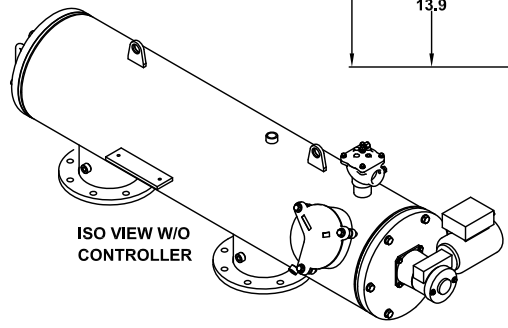
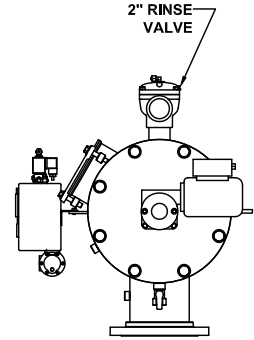
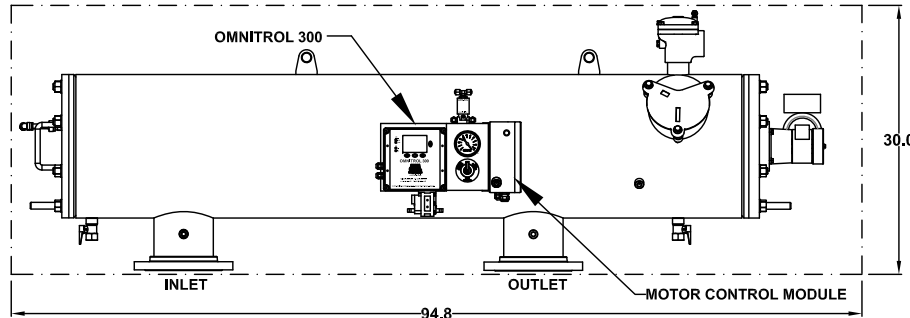
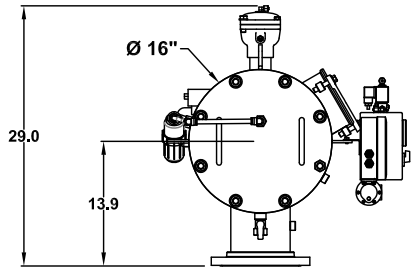
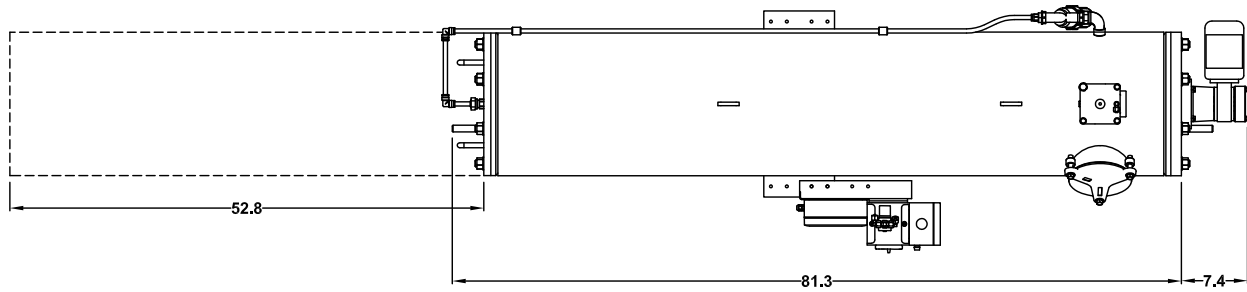

**TECHNICAL DATA**

MAXIMUM FLOW RATE:	800 G.P.M.
AVAILABLE SCREEN MICRON SIZES:	5, 10, 15, 25, 30, 40, 50, 80, 100, 120, 150, 200, 300, 400, 800, 1000, 1500, 3000
OPEN SCREEN AREA:	1240 SQ. INCHES
MAXIMUM WORKING PRESSURE:	150 PSIG
MINIMUM INLET PRESSURE REQUIRED DURING RINSE CYCLE:	30 PSIG
MAX. WORKING TEMPERATURE:	150°F
INLET/OUTLET FLANGES:	6" ANSI B16.5 150# RF
DRAIN VALVE CONNECTION:	2"
DRAIN HEADER SIZE:	2" MINIMUM
DRIVE MOTOR RATING:	1/3 HP, TEFC
AVAILABLE INPUT VOLTAGES TO CONTROLLER and MOTOR:	110-120 Vac - 60 Hz - 1 Phase or 220-240 Vac - 50 Hz - 1 Phase
APPROXIMATE WEIGHT - DRY:	640 LBS.
APPROXIMATE SHIPPING WEIGHT:	810 LBS.
APPROXIMATE WEIGHT FULL OF WATER:	1085 LBS.

**ALL DIMENSIONS IN INCHES UNLESS INDICATED**

Orival Inc. reserves the right to modify filter dimensions without prior notice.

**DATA SHEET**

**ORE/B-06-PX**

**AUTOMATIC SELF-CLEANING FILTER**

**ORIVAL, INC.**

213 S. VAN BRUNT ST.  
ENGLEWOOD, N.J. 07631

TEL (201) 568-3311, FAX (201) 568-1916

www.orival.com  
filters@orival.com