

FREE SPACE REQUIRED FOR MAINTENANCE

FREE SPACE REQUIRED FOR INSTALLATION

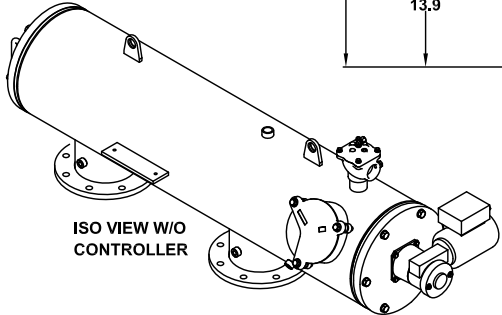
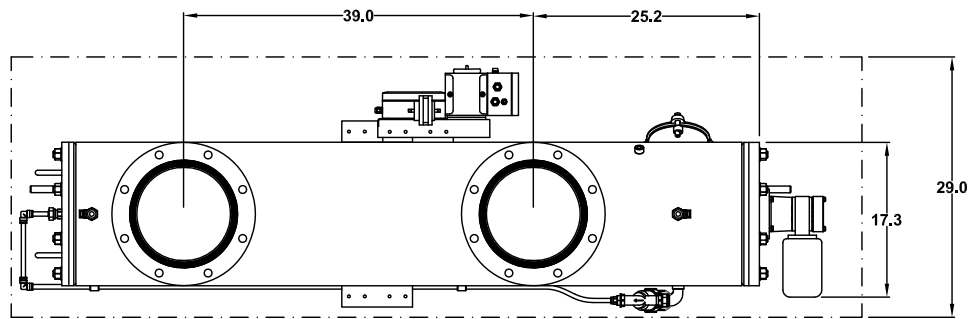
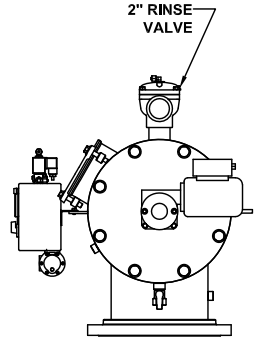
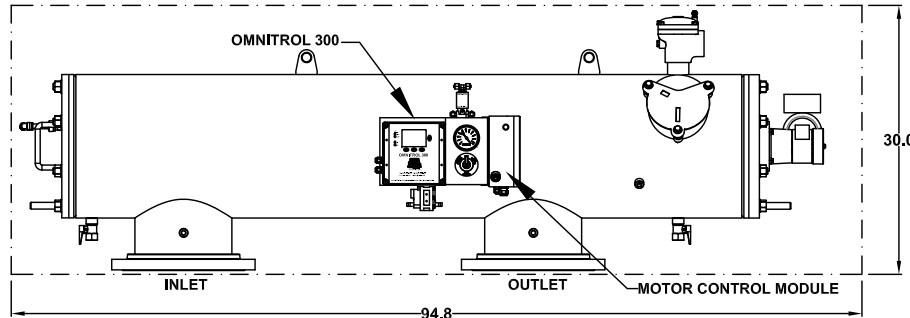
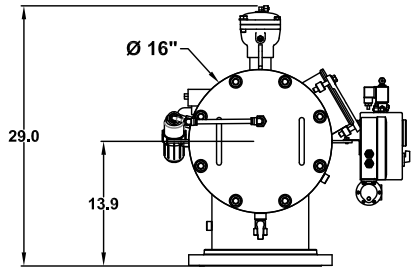
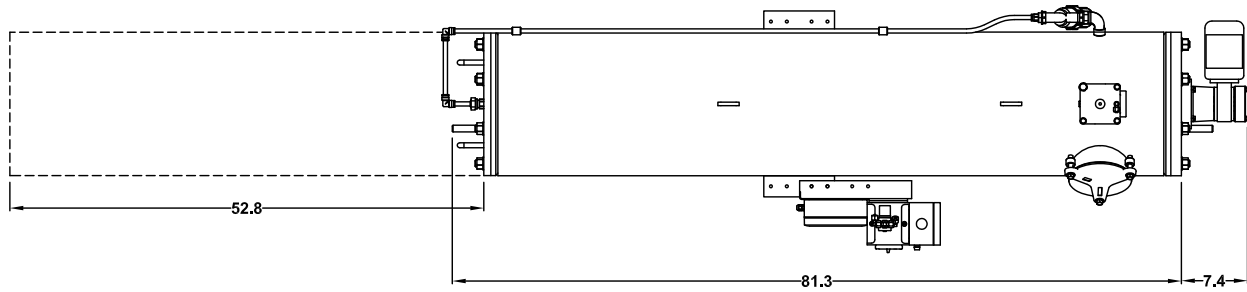

**TECHNICAL DATA**

|  |  |
|--|--|
| MAXIMUM FLOW RATE:                                 | 1760 G.P.M.  |
| AVAILABLE SCREEN MICRON SIZES:                     | 5, 10, 15, 25, 30, 40, 50, 80, 100, 120, 150, 200, 300, 400, 800, 1000, 1500, 3000 |
| OPEN SCREEN AREA:                                  | 1240 SQ. INCHES  |
| MAXIMUM WORKING PRESSURE:                          | 150 PSIG   |
| MINIMUM INLET PRESSURE REQUIRED DURING RINSE CYCLE | 30 PSIG  |
| MAX. WORKING TEMPERATURE:                          | 150°F  |
| INLET/OUTLET FLANGES:                              | 10" ANSI B16.5 150# RF   |
| DRAIN VALVE CONNECTION:                            | 2"   |
| DRAIN HEADER SIZE:                                 | 2" MINIMUM   |
| DRIVE MOTOR RATING:                                | 1/3 HP, TEFC   |
| AVAILABLE INPUT VOLTAGES TO CONTROLLER and MOTOR:  | 110-120 Vac - 60 Hz - 1 Phase or 220-240 Vac - 50 Hz - 1 Phase                     |
| APPROXIMATE WEIGHT - DRY:                          | 690 LBS.   |
| APPROXIMATE SHIPPING WEIGHT:                       | 860 LBS.   |
| APPROXIMATE WEIGHT FULL OF WATER:                  | 1135 LBS.  |

ALL DIMENSIONS IN INCHES UNLESS INDICATED  
Orival Inc. reserves the right to modify filter dimensions without prior notice.

**DATA SHEET**

**ORE/B-10-PE**  
AUTOMATIC SELF-CLEANING FILTER

**ORIVAL, INC.**  
213 S. VAN BRUNT ST.  
ENGLEWOOD, N.J. 07631  
TEL (201) 568-3311, FAX (201) 568-1916  
www.orival.com  
filters@orival.com