

FREE SPACE REQUIRED FOR MAINTENANCE

FREE SPACE REQUIRED FOR INSTALLATION

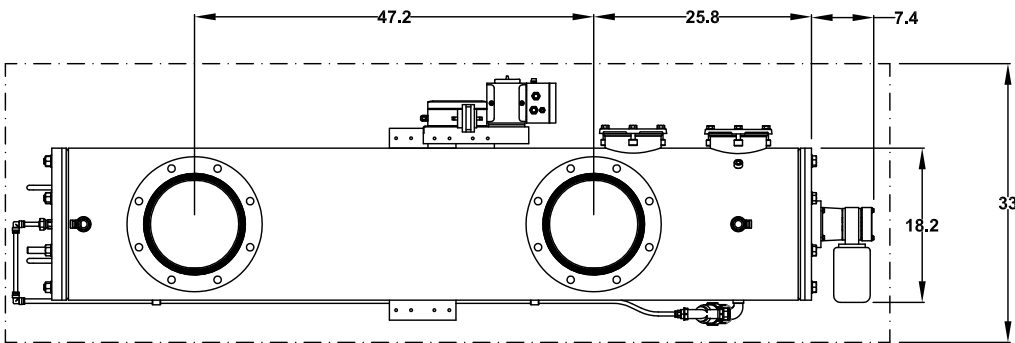
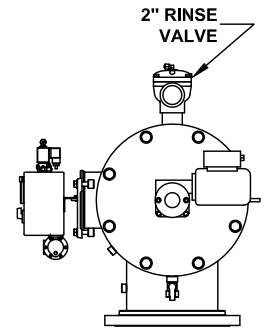
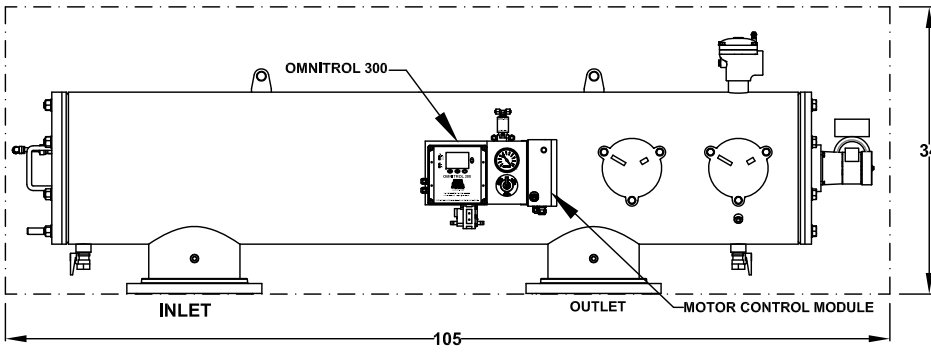
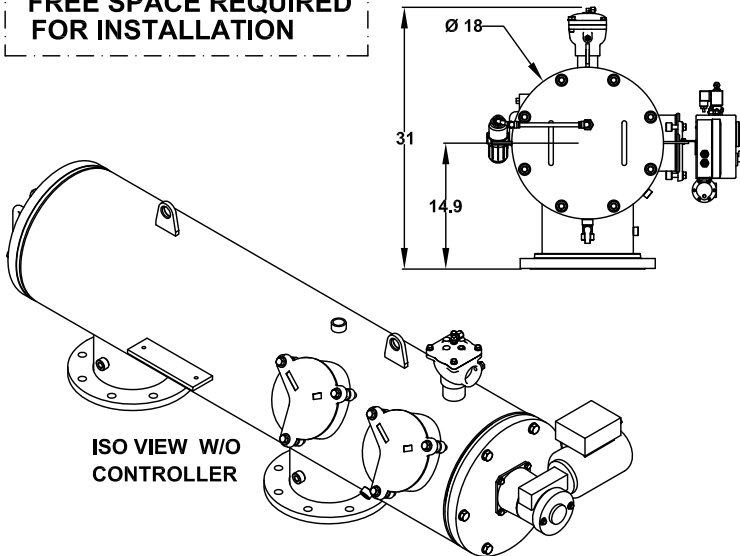

TECHNICAL DATA

| | |
|---|--|
| MAXIMUM FLOW RATE: | 2400 G.P.M. |
| AVAILABLE SCREEN MICRON SIZES: | 5, 10, 15, 25, 30, 40, 50, 80, 100, 120, 150, 200, 300, 400, 800, 1000, 1500, 3000 |
| OPEN SCREEN AREA: | 1560 SQ. INCHES |
| MAXIMUM WORKING PRESSURE: | 150 PSIG |
| MINIMUM INLET PRESSURE REQUIRED DURING RINSE CYCLE: | 30 PSIG |
| MAX. WORKING TEMPERATURE: | 150°F |
| INLET/OUTLET FLANGES: | 10" ANSI B16.5 150# RF |
| DRAIN VALVE CONNECTION: | 2" |
| DRAIN HEADER SIZE: | 2" MINIMUM |
| DRIVE MOTOR RATING: | 1/3 HP, TEFC |
| AVAILABLE INPUT VOLTAGES TO CONTROLLER and MOTOR: | 110-120 Vac - 60 Hz - 1 Phase or 220-240 Vac - 50 Hz - 1 Phase |
| APPROXIMATE WEIGHT - DRY: | 980 LBS. |
| APPROXIMATE SHIPPING WEIGHT: | 1190 LBS. |
| APPROXIMATE WEIGHT FULL OF WATER: | 1595 LBS. |

ALL DIMENSIONS IN INCHES UNLESS INDICATED
Orval Inc. reserves the right to modify filter dimensions without prior notice.

DATA SHEET
ORE/B-10-PX
AUTOMATIC SELF-CLEANING FILTER

ORIVAL, INC.
213 S. VAN BRUNT ST.
ENGLEWOOD, N.J. 07631
TEL (201) 568-3311, FAX (201) 568-1916
www.orival.com
filters@orival.com