

FREE SPACE REQUIRED  
FOR MAINTENANCE

FREE SPACE REQUIRED  
FOR INSTALLATION

ALL DIMENSIONS IN INCHES UNLESS INDICATED

Orival Inc. reserves the right to modify filter dimensions without prior notice.

### TECHNICAL DATA

MAXIMUM FLOW RATE:	3960 G.P.M.
AVAILABLE SCREEN MICRON SIZES:	5, 10, 15, 25, 30, 40, 50, 80, 100, 120, 150, 200, 400, 800, 1000, 1500, 3000
OPEN AREA STANDARD SCREEN :	1070 SQ. INCHES
OPEN AREA HIGH PERFORMANCE SINTERED MULTI-LAYERED SCREEN:	1605 SQ. INCHES
MAXIMUM WORKING PRESSURE:	150 PSIG
MINIMUM INLET PRESSURE REQUIRED DURING RINSE CYCLE:	30 PSIG
MAX. WORKING TEMPERATURE:	150°F
INLET/OUTLET FLANGES:	14" ANSI 150#
DRAIN VALVE CONNECTION:	3 X 2" THREADED
DRAIN HEADER SIZE:	4" MINIMUM
APPROX. EMPTY WEIGHT:	965 LBS.
APPROX. FULL OF WATER WEIGHT:	1910 LBS.

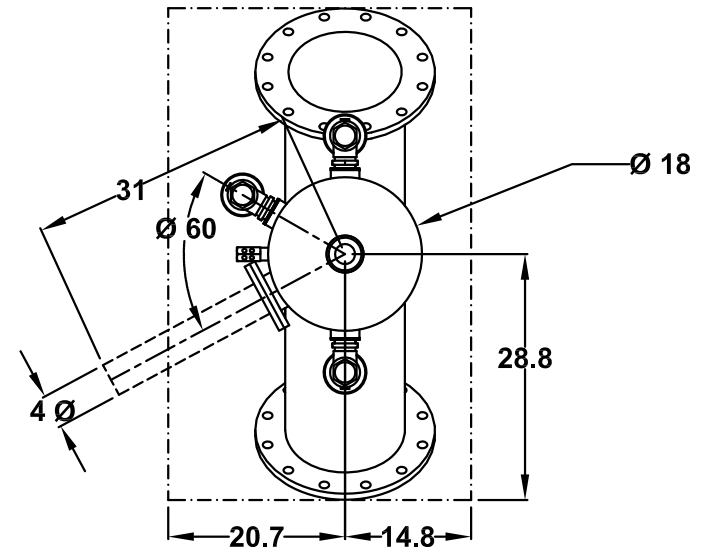
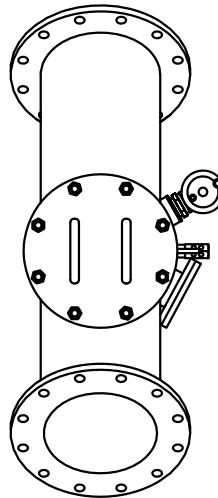

### DATA SHEET

# ORI-14-IS

AUTOMATIC SELF-CLEANING FILTER

REV 4/14

**ORIVAL, INC.**  
213 S. VAN BRUNT ST.  
ENGLEWOOD, N.J. 07631  
TEL (201) 568-3311, FAX (201) 568-1916  
www.orival.com, filters@orival.com