

**FREE SPACE REQUIRED
FOR MAINTENANCE**

**FREE SPACE REQUIRED
FOR INSTALLATION**

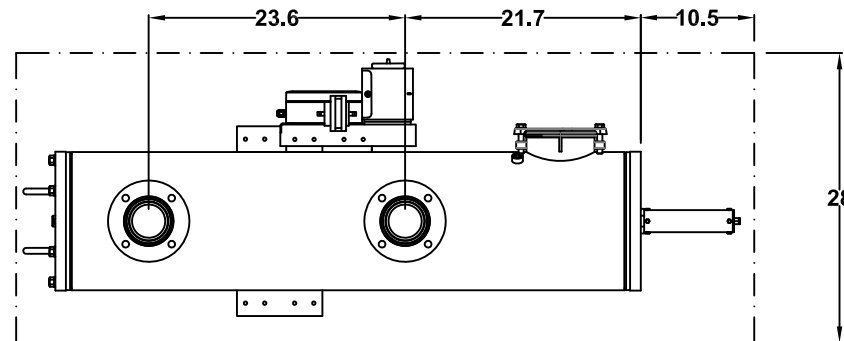
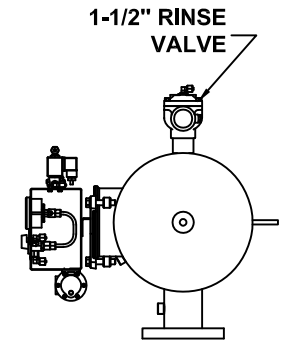
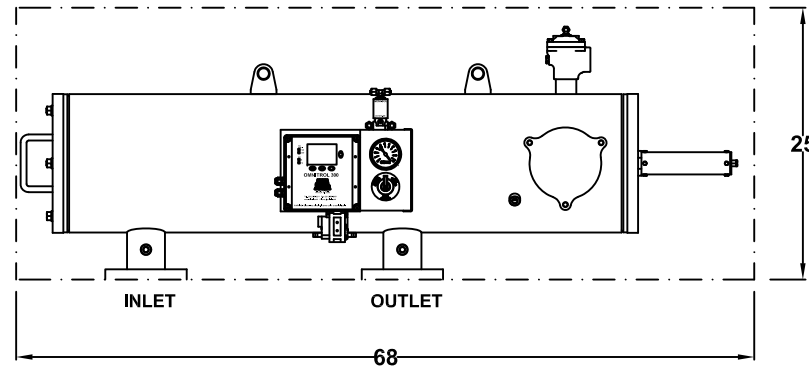
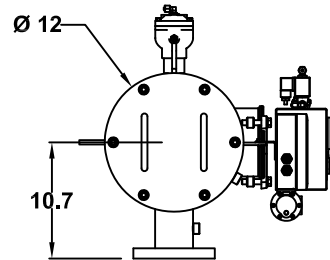
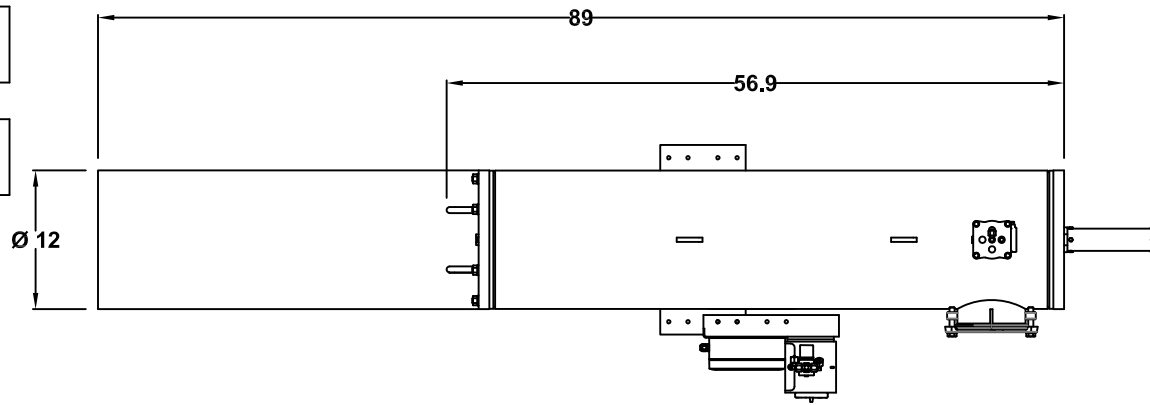

ALL DIMENSIONS IN INCHES UNLESS INDICATED
Orival Inc. reserves the right to modify filter dimensions without prior notice.

TECHNICAL DATA

MAXIMUM FLOW RATE:	250 G.P.M.
AVAILABLE SCREEN MICRON SIZES:	5, 10, 15, 25, 30, 40, 50, 80, 100, 120, 150, 200, 300, 400, 800, 1000, 1500, 3000
OPEN SCREEN AREA STANDARD SCREEN:	413 SQ. INCHES
OPEN SCREEN AREA HIGH PERFORMANCE MULTI-LAYERED SINTERED SCREEN	620 SQ. INCHES
MAXIMUM WORKING PRESSURE:	150 PSIG
MINIMUM INLET PRESSURE REQUIRED DURING RINSE CYCLE	30 PSIG
MAX. WORKING TEMPERATURE:	150°F
INLET/OUTLET FLANGES:	3" ANSI 150# RF
DRAIN VALVE CONNECTION:	1-1/2"
DRAIN HEADER SIZE:	1-1/2" MINIMUM
APPROXIMATE WEIGHT - DRY:	370 LBS.
APPROXIMATE SHIPPING WEIGHT:	460 LBS.
APPROXIMATE WEIGHT FULL OF WATER:	475 LBS.

DATA SHEET

ORZ-03-PE

AUTOMATIC SELF-CLEANING FILTER

ORIVAL, INC.

213 S. VAN BRUNT ST.
ENGLEWOOD, N.J. 07631

TEL (201) 568-3311, FAX (201) 568-1916

www.orival.com
filters@orival.com