

FREE SPACE REQUIRED
FOR MAINTENANCE

FREE SPACE REQUIRED
FOR INSTALLATION

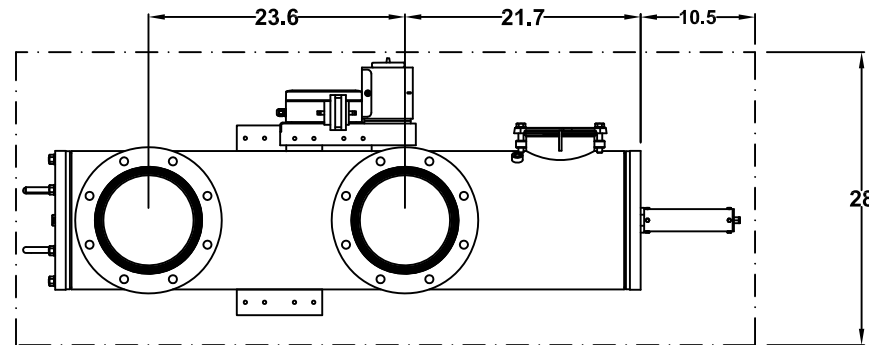
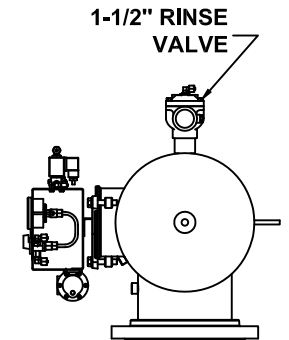
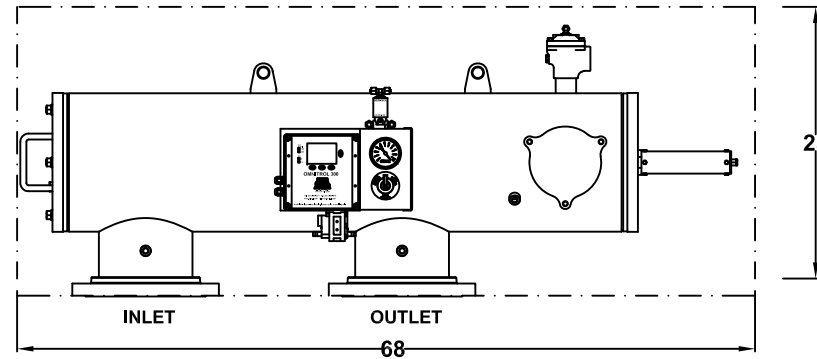
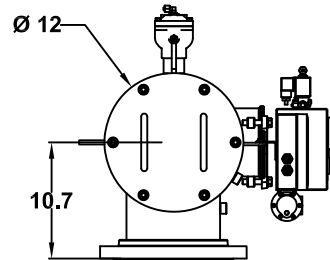
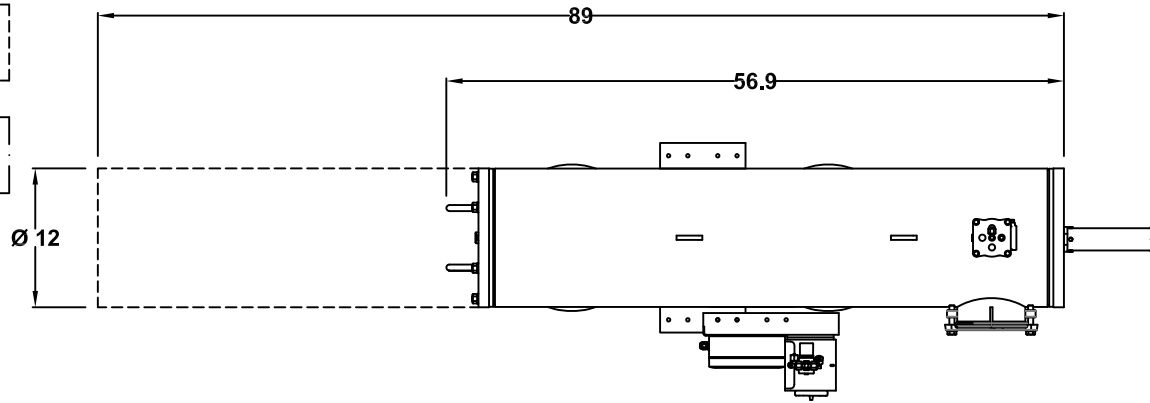

ALL DIMENSIONS IN INCHES UNLESS INDICATED
Orival Inc. reserves the right to modify filter dimensions without prior notice.

TECHNICAL DATA

MAXIMUM FLOW RATE:	1320 G.P.M.
AVAILABLE SCREEN MICRON SIZES:	5, 10, 15, 25, 30, 40, 50, 80, 100, 120, 150, 200, 300, 400, 800, 1000, 1500, 3000
OPEN SCREEN AREA STANDARD SCREEN:	413 SQ. INCHES
OPEN AREA HIGH PERFORMANCE MULTI LAYERED SINTERED SCREEN:	620 SQ. INCHES
MAXIMUM WORKING PRESSURE:	150 PSIG
MINIMUM INLET PRESSURE REQUIRED DURING RINSE CYCLE	30 PSIG
MAX. WORKING TEMPERATURE:	150°F
INLET/OUTLET FLANGES:	6" ANSI 150# RF
DRAIN VALVE CONNECTION:	1-1/2"
DRAIN HEADER SIZE:	1-1/2" MINIMUM
APPROXIMATE WEIGHT - DRY:	430 LBS.
APPROXIMATE SHIPPING WEIGHT:	520 LBS.
APPROXIMATE WEIGHT FULL OF WATER:	535 LBS.

DATA SHEET

ORZ-08-PM

AUTOMATIC SELF-CLEANING FILTER

ORIVAL, INC.

213 S. VAN BRUNT ST.
ENGLEWOOD, N.J. 07631

TEL (201) 568-3311, FAX (201) 568-1916

www.orival.com
filters@orival.com