

**FREE SPACE REQUIRED FOR MAINTENANCE**

**FREE SPACE REQUIRED FOR INSTALLATION**

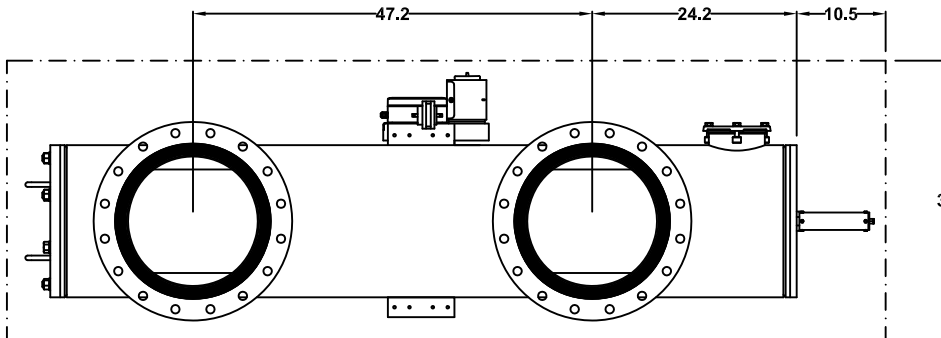
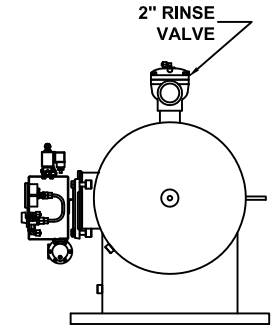
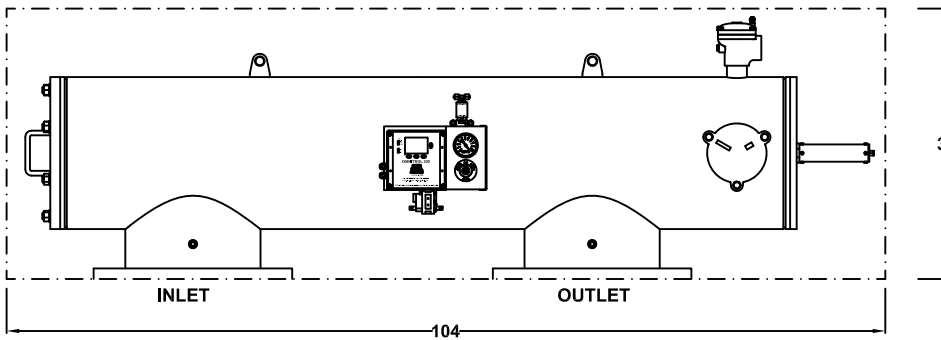
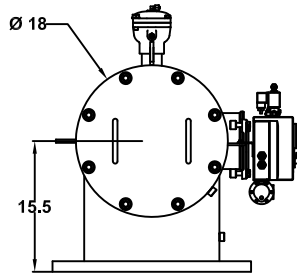

## TECHNICAL DATA

MAXIMUM FLOW RATE:	4250 G.P.M.
AVAILABLE SCREEN MICRON SIZES:	5, 10, 15, 25, 30, 40, 50, 80, 100, 120, 150, 200, 300, 400, 800, 1000, 1500, 3000
OPEN SCREEN AREA STANDARD SCREEN:	1039 SQ. INCHES
OPEN SCREEN AREA HIGH PERFORMANCE MULTI LAYERED SINTERED SCREEN:	1560 SQ. INCHES
MAXIMUM WORKING PRESSURE:	150 PSIG
MINIMUM INLET PRESSURE REQUIRED DURING RINSE CYCLE	30 PSIG
MAX. WORKING TEMPERATURE:	150°F
INLET/OUTLET FLANGES:	14" ANSI 150# RF
DRAIN VALVE CONNECTION:	2"
DRAIN HEADER SIZE:	2" MINIMUM
APPROXIMATE WEIGHT - DRY:	1030 LBS.
APPROXIMATE SHIPPING WEIGHT:	1240 LBS.
APPROXIMATE WEIGHT FULL OF WATER:	1635 LBS.

**ALL DIMENSIONS IN INCHES UNLESS INDICATED**

Orival Inc. reserves the right to modify filter dimensions without prior notice.

## DATA SHEET

# ORZ-14-PE

**AUTOMATIC SELF-CLEANING FILTER**

**ORIVAL, INC.**

213 S. VAN BRUNT ST.

ENGLEWOOD, N.J. 07631

TEL (201) 568-3311, FAX (201) 568-1916

[www.orival.com](http://www.orival.com)

[filters@orival.com](mailto:filters@orival.com)